

THE AVIATOR

THE BUNGALOWS AT HARBOUR LANDING

1,590 SQ. FT

3 Bed | 2 Bath

FEATURES:

- Laundry Room
- Primary Ensuite & Walk-In Closet
- Attached Double Garage
- 12'x8' Concrete Patio
- Finished Basement Option

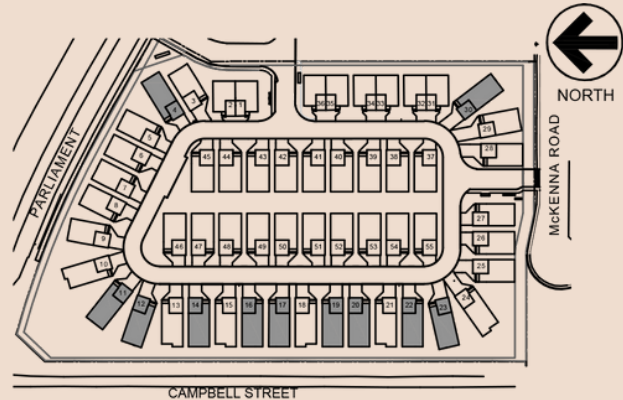

LOWER LEVEL - OPTIONAL DEVELOPMENT

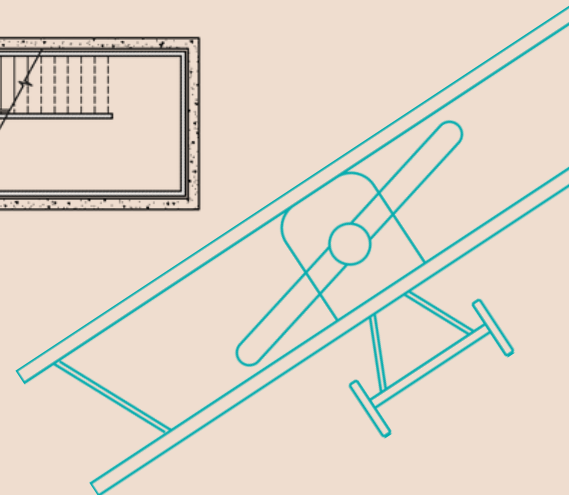
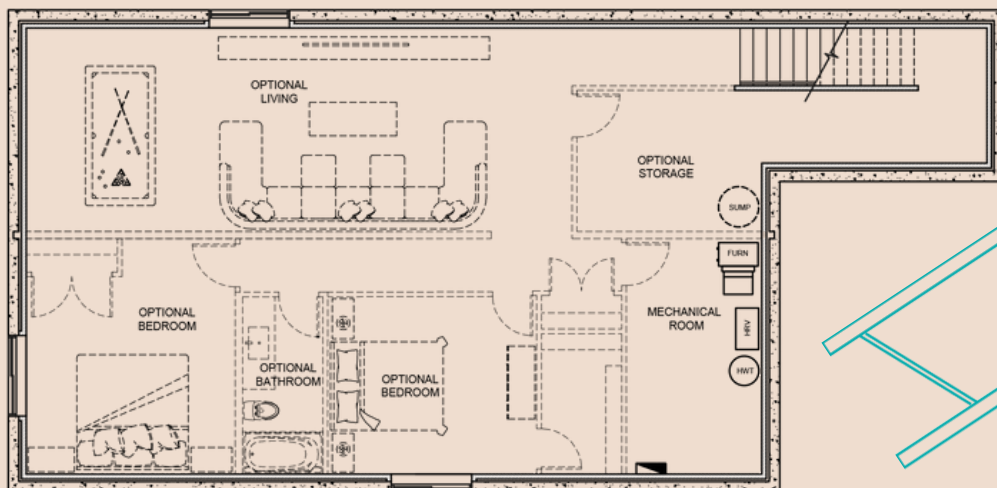

THEBUNGALOWSREGINA.CA

*The developer reserves the right to change plans, specifications, features, materials, and dimensions without notice in its sole discretion. All renderings, colour schemes, floor plans, maps and displays are artists' conceptions and for illustration purposes only. See sales representative for full details. E&OE.